

Kelvion



avrora-arm.ru
+7 (495) 956-62-18

Kelvion KEC Commercial air cooler

**HIGH EFFICIENCY,
HIGH PERFORMANCE**



Kelvion



EXPERTS IN HEAT EXCHANGE – SINCE 1920

Welcome to Kelvion. Heat exchange is our business. Worldwide. As a market leader in the technology sector, we have been producing heat exchangers for virtually every conceivable industrial application since the 1920s, including tailor-made solutions suited for the most complex environmental conditions – as of 2015 under the name of Kelvion.

With one of the most comprehensive ranges of heat exchangers in the world, which includes compact finned-tube heat exchangers, plate heat exchangers, single tube heat exchangers, shell and tube heat exchangers, transformer cooling systems and wet cooling towers, we are a sought after partner in a wide variety of industries, such as: the energy industry, the oil and gas industry, the chemical industry, the shipbuilding sector, the food and beverage industry, the heavy industry, the sugar industry, the transport sector, as well as building and refrigeration technology.

Many years of experience and in-depth expert knowledge make us specialists in this field.

Our heat exchangers are designed for the requirements of the respective process, thereby ensuring optimum energy efficiency and reliability for all market segments. This provides our customers with a technological advantage that reduces operating costs and has a lasting effect.

A reliable after-sales service is essential with regard to customer loyalty and retention. We have a worldwide service network at our disposal. Our engineers are thereby able to carry out maintenance work and complete repairs on-site at a customer's premises. This prevents unnecessary downtime – because we are highly committed to earning your trust.

Kelvion – Experts in Heat Exchange.

KELVION – A TRIBUTE TO LORD KELVIN (1824 - 1907)



Lord Kelvin formulated the laws of thermodynamics and absolute units of temperature are stated in kelvin, in his honor.

OUR LOGO – INSPIRED FROM THE SCHEMATIC FOR HEAT EXCHANGER

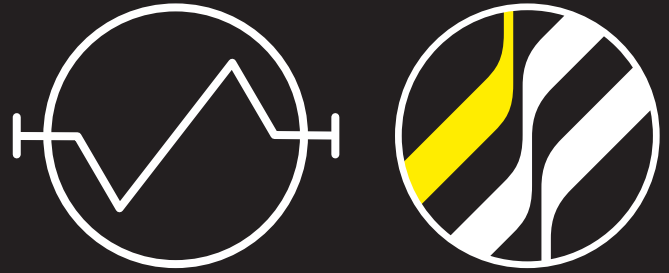

67 BRANCHES AND SALES PARTNERS WORLDWIDE

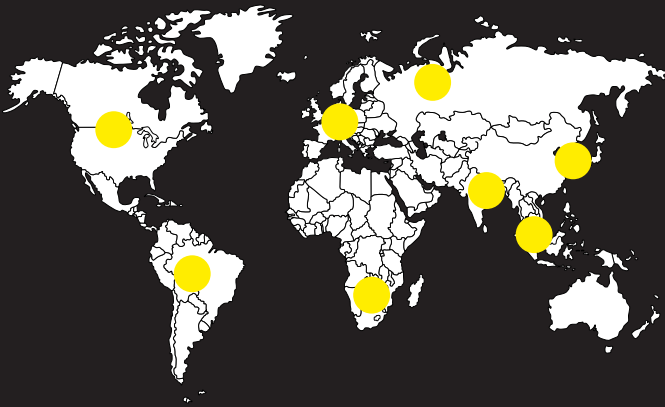

4,500 EMPLOYEES WORLDWIDE

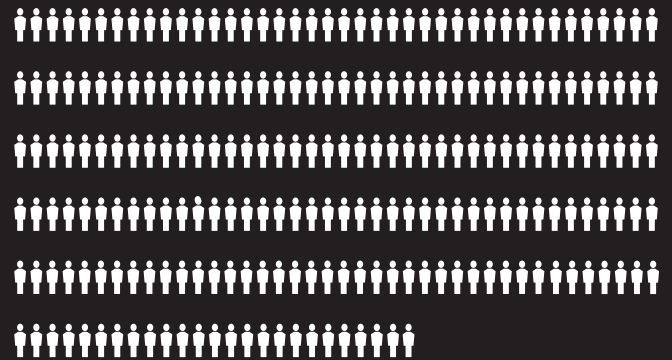

YOUR MARKETS ARE OUR MARKETS



Chemicals



Food & Beverages



Heavy Industry



HVAC



Refrigeration



Marine



Oil & Gas



Power



Sugar











Transportation

KELVION HAS A LONG HISTORY



COMMERCIAL AIR COOLER RANGE

MODEL	NO.FANS	CONFIGURATION	EUROVENT	SUPPLY	EC FANS	ELECTRIC DEFROST	HEAVY ELECTRIC DEFROST	HOT GAS A/B/C/D DEFROST	CO2	FIN MATERIAL	CAPACITY
TEC 	1 - 3		✓	1 ph	✓	✓ kit	X	X	✓	AL, AV	0.5 - 3.4kW (CO ₂) 0.34 - 3.8kW
KEC 	1 - 3		✓	1 ph	✓	✓	X	✓	✓	AL, AV	1.2 - 10.7kW (CO ₂) 1 - 9.9kW
KMe 	1 - 4		✓	1 & 3ph	○	✓	✓	✓	✓	AL, AV	5.8 - 28kW (CO ₂) 5.9 - 48.1kW
KDC 	1 - 6		✓	1 ph	✓	✓	X	X	✓	AL, AV	1.4 - 23kW (CO ₂) 1.7 - 23kW

✓ YES X NO ○ OPTION

KEC SPECIFICATION

CASEWORK: The casework is formed from galvanized steel and finished with oven cured white epoxy powder paint (RAL 9010). The construction is both rigid and versatile, giving the installer and users flexibility and confidence in service life. Connections and junction boxes for the unit are easily accessible through removable side panels which are fixed in place using easy-alignment keyhole slots.

The drain tray is fabricated from galvanised painted steel and is supplied loose, once the unit is installed on site the drain connection can be fitted to the tray and the tray fitted to the unit in its operating position.

FANS: The KEC cooler from Kelvion, utilises EC fan sets as standard. The EC motors can accept 196-253V 1Ph at 50/60Hz with built in thermal protection.

- Fan diameter: 300mm
- Number of Blades: 5
- Guard: Metal Wire (Black)
- Fan Rotation: Clockwise when facing air stream
- Motor Rating: IP54
- Aluminium orifice
- Temperature Range :40°C to +40°C

COIL: The coil used in the KEC range balances surface and defrost efficiency and is the result of extensive R&D. The coil is assembled in one block, is available as either 4 or 6 rows deep and uses aluminium fins as standard. The coil has inner groove tubes on 43mm equilateral centres mechanically bonded to the fin.

- Manufactured from ½" Tube
- Tube Pitch Across Airflow: 43mm
- Tube Pitch In Direction of Airflow: 37.2mm
- Fin Spacing (s): 4mm, 6mm and 8mm
- Fin Enhancements: Light Ripple
- Formed heater holes

CO₂ OPTION: Kelvion has delivered a new generation of environmentally friendly CO₂ unit coolers, with a capacity range of 0.9 - 9.9kW. Using the same robust case construction as the standard KEC range and utilising the same high efficiency fan sets, the difference lies in the coil itself. To develop this coil technology specifically for a range of CO₂ applications, extensive testing and analysis was essential to ensure they deliver the performance required across a wide range of potential operating conditions. All units are tested to 1.43 x maximum operating pressure before delivery, and 3 standard operating pressure are offered as standard:

- 57 Bar = KEC-LP LX
- 80 Bar = KEC - MP MX
- 90 Bar = KEC-HP HX

KEC AIR COOLER







APPLICATION & BENEFITS

- ▶ **The KEC cooler is part of the next generation of Unit Coolers by Kelvion:** with market leading performance, noise levels and energy efficiency.
- ▶ **The popular KEC range:** suitable for high, medium and low temperature applications in the commercial refrigeration sector.
- ▶ **Fans are the highest quality and efficiency:** The KEC Cooler from Kelvion utilises EC fan sets as standard. The EC motors can accept 196-253V 1Ph at 50/60Hz with built in thermal protection.
- ▶ **Enhanced standard KEC range for CO₂ refrigeration applications.** Environmentally friendly CO₂ unit coolers, with a capacity range of 0.9 - 9.9kW. Using the same robust case construction as the standard KEC range and utilising the same high efficiency fan sets, the difference lies in the coil itself.
- ▶ **Casework:** The construction is both rigid and versatile, giving the installer and users flexibility and confidence in service life.
- ▶ **Eurovent certify-all:** independent certification for thermal performance, power consumption, sound data and unit air volumes for standard products under scheme limits.

CAPACITY RANGE

HFO/HFK 1.2 kW - 10.5 kW
 $t_{Li}=0^{\circ}\text{C} \mid t_o=-8^{\circ}\text{C} \mid \text{DT}=8\text{K} \mid [\text{SC2}] \mid \text{R404A}$

 **0.9 kW - 9.9 kW**
 $t_{Li}=0^{\circ}\text{C} \mid t_o=8^{\circ}\text{C} \mid \text{DT}=8\text{K} \mid [\text{SC2}]$

HEAT EXCHANGE

- ▶ Fin Type: D
- ▶ Tube Diameter: [mm]
12
- ▶ Standard Fin spacing: [mm]
4 | 6 | 8
- ▶ Fin Enhancements: Light Ripple

VARIANTS & ACCESSORIES

- ▶ Fan sets
- ▶ Coil heater
- ▶ Model options: KEC-LP, KEC-MP, KEC-LX, KEC-MX, KEC-HX

DEFROST

DEFROST	FAN	COIL	DRIP TRAY
Standard Electric		✓	✓
Heavy Electric		X	
Hot gas		✓	✓

FAN

▶ EC Standard		▶ Ø 230 mm ▶ IP54 ▶ 1 phase
---------------	---	-----------------------------------

MATERIALS

MATERIAL	TUBE	FINS	CASING	END PLATE
Copper (Cu)	<input checked="" type="checkbox"/>	✓		
Aluminium (Al)		<input checked="" type="checkbox"/>		<input checked="" type="checkbox"/>
Aluminium Epoxy (AV)		✓		
Galvanised Steel			<input checked="" type="checkbox"/>	

Standard | Available as a variant

REFRIGERANT DATA

REFRIGERATION	R404A	R134A	R507A	R407A/F	R407C
Capacity factor (dew point, DT1)	1.00	0.91	0.97	1.24*	1.26*
Refrigerant charge density (kg/dm ³)	0.312	0.338	0.313	0.332	0.332

* Capacity factors for refrigerants with high glide apply only at the nominal rating condition.
Refrigerant charge densities are based on 25% of the internal volume being liquid.

DESIGNATION

The model number indicates the casework model size and other relevant information, for example: -

PART NUMBER	KEC	35	-	4	L	AL
Range	KEC, KEC-LP, KEC-MP, KEC-LX, KEC-MX, KEC-HX <input type="checkbox"/>					
Model	10, 15, 20, 25, 30, 35 , 40, 45, 55, 70					
Fin Spacing (Type for CO ₂)	4mm , 6mm, 8mm					
Defrost:	X = direct expansion, L = 57 bar, M = 80 bar, H = 90 bar No defrost, L = Standard Electric defrost, HGD = Hot Gas Coil & tray, HGE = Hot Gas Coil & Electric tray. Each gas defrost option is followed with either an A / B / C / D, to designate the circuiting option.					
Fin Material	AL = Aluminium					

SELECTION DATA

FIN SPACING	MODEL	CAPACITY 8K DT1 R404A *	MOTOR DETAILS 230V - 1PH - 50Hz					FAN DATA			CONNECTION		INTER- NAL VOLUME	SURFACE AREA	REF CHARGE	WEIGHT
			NO. OF FANS	POWER INPUT	FLC PER FAN	SC PER FAN	SPEED	AIR VOLUME	AIR THROW ***	NOISE LEVEL @ 3M **	INLET	OUTLET				
				W	Amps	Amps	RPM	m ³ /s	m	dB(A)						
		kW										dm ³	m ²	kg	kg	
4mm	KEC10-4	1.65	1	33	0.35	0.50	1370	0.28	16.0	44	1/2"	1/2"	1.4	8.5	0.5	27
	KEC15-4	2.01	1	33	0.35	0.50	1370	0.28	16.0	44	1/2"	1/2"	1.9	10.0	0.6	28
	KEC20-4	2.35	1	33	0.35	0.50	1370	0.29	16.0	44	1/2"	5/8"	2.5	13.7	0.8	33
	KEC25-4	3.00	1	77	0.70	1.00	1750	0.42	22.0	52	1/2"	5/8"	2.5	13.7	0.8	33
	KEC30-4	3.73	1	77	0.70	1.00	1750	0.40	22.0	52	1/2"	7/8"	3.8	20.5	1.2	35
	KEC35-4	4.57	2	66	0.35	0.50	1370	0.58	16.0	47	1/2"	7/8"	4.3	24.9	1.4	47
	KEC40-4	5.84	2	154	0.70	1.00	1750	0.83	22.0	55	1/2"	7/8"	4.3	24.9	1.4	47
	KEC45-4	6.99	2	154	0.70	1.00	1750	0.81	22.0	55	1/2"	7/8"	6.5	37.4	2.1	53
	KEC55-4	8.79	3	231	0.70	1.00	1750	1.25	22.0	57	1/2"	7/8"	6.3	37.4	2.0	67
	KEC70-4	10.51	3	231	0.70	1.00	1750	1.21	22.0	57	5/8"	7/8"	9.4	56.0	3.0	74
6mm	KEC10-6	1.34	1	33	0.35	0.50	1370	0.31	16.0	44	1/2"	1/2"	1.4	5.8	0.5	27
	KEC15-6	1.72	1	33	0.35	0.50	1370	0.31	16.0	44	1/2"	1/2"	1.9	6.8	0.6	28
	KEC20-6	1.99	1	33	0.35	0.50	1370	0.32	16.0	44	1/2"	5/8"	2.5	9.4	0.8	33
	KEC25-6	2.38	1	77	0.70	1.00	1750	0.43	22.0	52	1/2"	5/8"	2.5	9.4	0.8	33
	KEC30-6	3.16	1	77	0.70	1.00	1750	0.42	22.0	52	1/2"	7/8"	3.8	14.1	1.2	35
	KEC35-6	3.85	2	66	0.35	0.50	1370	0.63	16.0	47	1/2"	7/8"	4.3	17.0	1.4	47
	KEC40-6	4.63	2	154	0.70	1.00	1750	0.85	22.0	55	1/2"	7/8"	4.3	17.0	1.4	47
	KEC45-6	5.97	2	154	0.70	1.00	1750	0.83	22.0	55	1/2"	7/8"	6.5	25.6	2.1	53
	KEC55-6	7.00	3	231	0.70	1.00	1750	1.28	22.0	57	1/2"	7/8"	6.3	25.6	2.0	67
	KEC70-6	8.98	3	231	0.70	1.00	1750	1.25	22.0	57	5/8"	7/8"	9.4	38.3	3.0	74
8mm	KEC10-8	1.17	1	33	0.35	0.50	1370	0.32	16.0	44	1/2"	1/2"	1.4	4.4	0.5	27
	KEC15-8	1.52	1	33	0.35	0.50	1370	0.32	16.0	44	1/2"	1/2"	1.9	5.2	0.6	28
	KEC20-8	1.74	1	33	0.35	0.50	1370	0.33	16.0	44	1/2"	5/8"	2.5	7.2	0.8	33
	KEC25-8	2.06	1	77	0.70	1.00	1750	0.44	22.0	52	1/2"	5/8"	2.5	7.2	0.8	33
	KEC30-8	2.75	1	77	0.70	1.00	1750	0.43	22.0	52	1/2"	7/8"	3.8	10.8	1.2	35
	KEC35-8	3.30	2	66	0.35	0.50	1370	0.65	16.0	47	1/2"	7/8"	4.3	13.1	1.4	47
	KEC40-8	3.98	2	154	0.70	1.00	1750	0.86	22.0	55	1/2"	7/8"	4.3	13.1	1.4	47
	KEC45-8	5.31	2	154	0.70	1.00	1750	0.86	22.0	55	1/2"	7/8"	6.5	19.7	2.1	53
	KEC55-8	6.01	3	231	0.70	1.00	1750	1.31	22.0	57	1/2"	7/8"	6.3	19.7	2.0	67
	KEC70-8	7.97	3	231	0.70	1.00	1750	1.29	22.0	57	5/8"	7/8"	9.4	29.5	3.0	74

NOTES: Rating conditions: The duties shown in this brochure are at EN 328 Standard Condition 2 (-8°C saturated suction temperature, 0°C air entering). For data on refrigerants not shown, please contact your supplier.

- * DT1 is the difference between the entering air temperature and the saturated suction temperature at the outlet of the cooler.
- ** Noise levels are based on free field conditions at a distance of 3m. Actual noise levels will depend upon cold store construction, store loading and the number of coolers installed.
- *** Terminal air velocity 0.25m/s, free air conditions at 10°C. Air throw cannot be considered an absolute value because many factors have a substantial effect on the distance achieved.

ELECTRIC DEFROST DATA

MODEL	230V-1PH-50/60HZ		STANDARD
	Coil	Pan	Total
	kW	W	kW
KEC10-*	0.68	0.34	1.02
KEC15-*	0.68	0.34	1.02
KEC20-*	0.92	0.46	1.38
KEC25-*	0.92	0.46	1.38
KEC25-*	0.92	0.46	1.38
KEC35-*	1.6	0.8	2.4
KEC40-*	1.6	0.8	2.4
KEC45-*	1.6	0.8	2.4
KEC55-*	2.4	1.2	3.6
KEC70-*	2.4	1.2	3.6

CO2 KEC DIRECT EXPANSION

LX (57BAR), MX (80 BAR), HX (90 BAR)

FIN SPACING	MODEL	CAPACITY 8K DT1 DX CO2 *	MOTOR DETAILS 230V - 1PH - 50Hz					FAN DATA			CONNECTION		INTER- NAL VOLUME	SURFACE AREA	REF CHARGE	WEIGHT
			NO. OF FANS	POWER INPUT	FLC PER FAN	SC PER FAN	SPEED	AIR VOLUME	AIR THROW ***	NOISE LEVEL @ 3M **	INLET	OUTLET				
				W	Amps	Amps	RPM	m ³ /s	m	dB(A)						
		kW										dm ³	m ²	kg	kg	
4mm	KEC-*X10-4	1.40	1	33	0.35	0.50	1370	0.28	16	44	1/2"	5/8"	2.0	7.5	0.9	29
	KEC-*X15-4	1.70	1	33	0.35	0.50	1370	0.28	16	44	1/2"	5/8"	2.0	10.0	0.9	30
	KEC-*X20-4	2.00	1	33	0.35	0.50	1370	0.29	16	44	1/2"	5/8"	3.0	13.7	1.3	37
	KEC-*X25-4	2.50	1	77	0.70	1.00	1750	0.42	22	52	1/2"	5/8"	3.0	13.7	1.3	37
	KEC-*X30-4	3.10	1	77	0.70	1.00	1750	0.40	22	52	1/2"	5/8"	4.0	20.5	1.7	41
	KEC-*X35-4	4.00	2	66	0.35	0.50	1370	0.58	16	47	1/2"	5/8"	5.0	24.9	2.2	54
	KEC-*X40-4	5.20	2	154	0.70	1.00	1750	0.83	22	55	1/2"	5/8"	5.0	24.9	2.2	54
	KEC-*X45-4	6.90	2	154	0.70	1.00	1750	0.81	22	55	1/2"	5/8"	7.0	37.3	3.0	62
	KEC-*X55-4	8.60	3	231	0.70	1.00	1750	1.25	22	57	1/2"	5/8"	6.0	37.3	2.6	76
	KEC-*X70-4	9.90	3	231	0.70	1.00	1750	1.21	22	57	1/2"	5/8"	9.0	56.0	3.9	89
6mm	KEC-*X10-6	1.20	1	33	0.35	0.50	1370	0.31	16	44	1/2"	5/8"	2.0	5.1	0.9	29
	KEC-*X15-6	1.50	1	33	0.35	0.50	1370	0.31	16	44	1/2"	5/8"	2.0	6.8	0.9	30
	KEC-*X20-6	1.80	1	33	0.35	0.50	1370	0.32	16	44	1/2"	5/8"	3.0	9.4	1.3	37
	KEC-*X25-6	2.10	1	77	0.70	1.00	1750	0.43	22	52	1/2"	5/8"	3.0	9.4	1.3	37
	KEC-*X30-6	2.70	1	77	0.70	1.00	1750	0.42	22	52	1/2"	5/8"	4.0	14.0	1.7	41
	KEC-*X35-6	3.40	2	66	0.35	0.50	1370	0.63	16	47	1/2"	5/8"	5.0	17.0	2.2	54
	KEC-*X40-6	4.20	2	154	0.70	1.00	1750	0.85	22	55	1/2"	5/8"	5.0	17.0	2.2	54
	KEC-*X45-6	6.00	2	154	0.70	1.00	1750	0.83	22	55	1/2"	5/8"	7.0	25.5	3.0	62
	KEC-*X55-6	7.00	3	231	0.70	1.00	1750	1.28	22	57	1/2"	5/8"	6.0	25.5	2.6	76
	KEC-*X70-6	8.40	3	231	0.70	1.00	1750	1.25	22	57	1/2"	5/8"	9.0	38.3	3.9	89
8mm	KEC-*X10-8	0.90	1	33	0.35	0.50	1370	0.32	16	44	1/2"	5/8"	2.0	3.9	0.9	29
	KEC-*X15-8	1.30	1	33	0.35	0.50	1370	0.32	16	44	1/2"	5/8"	2.0	5.2	0.9	30
	KEC-*X20-8	1.60	1	33	0.35	0.50	1370	0.33	16	44	1/2"	5/8"	3.0	7.2	1.3	37
	KEC-*X25-8	1.80	1	77	0.70	1.00	1750	0.44	22	52	1/2"	5/8"	3.0	7.2	1.3	37
	KEC-*X30-8	2.40	1	77	0.70	1.00	1750	0.43	22	52	1/2"	5/8"	4.0	10.8	1.7	41
	KEC-*X35-8	3.00	2	66	0.35	0.50	1370	0.65	16	47	1/2"	5/8"	5.0	13.1	2.2	54
	KEC-*X40-8	3.60	2	154	0.70	1.00	1750	0.86	22	55	1/2"	5/8"	5.0	13.1	2.2	54
	KEC-*X45-8	5.20	2	154	0.70	1.00	1750	0.86	22	55	1/2"	5/8"	7.0	19.6	3.0	62
	KEC-*X55-8	6.10	3	231	0.70	1.00	1750	1.31	22	57	1/2"	5/8"	6.0	19.6	2.6	76
	KEC-*X70-8	7.90	3	231	0.70	1.00	1750	1.29	22	57	1/2"	5/8"	9.0	29.4	3.9	89

NOTES: Rating conditions: The duties shown in this brochure are at EN 328 Standard Condition 2 (-8°C saturated suction temperature, 0°C air entering). For data on refrigerants not shown, please contact your supplier.

- * DT1 is the difference between the entering air temperature and the saturated suction temperature at the outlet of the cooler.
- ** Noise levels are based on free field conditions at a distance of 3m. Actual noise levels will depend upon cold store construction, store loading and the number of coolers installed.
- *** Terminal air velocity 0.25m/s, free air conditions at 10°C. Air throw cannot be considered an absolute value because many factors have a substantial effect on the distance achieved.

DIMENSIONS

CEILING MOUNT OPERATION

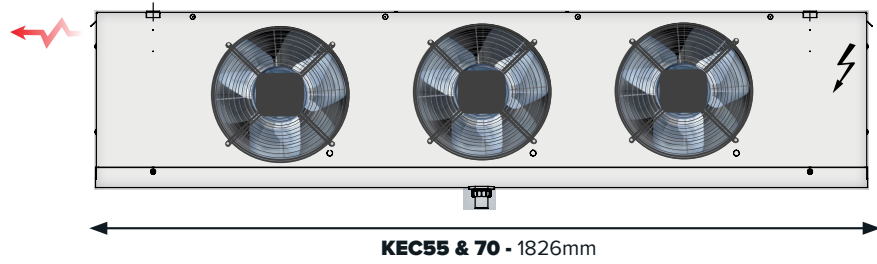
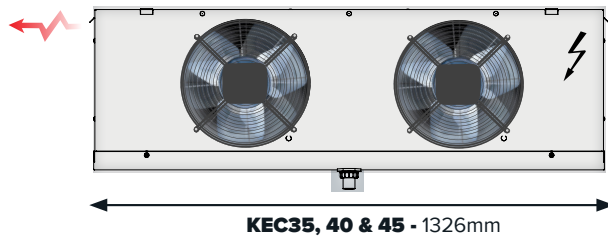
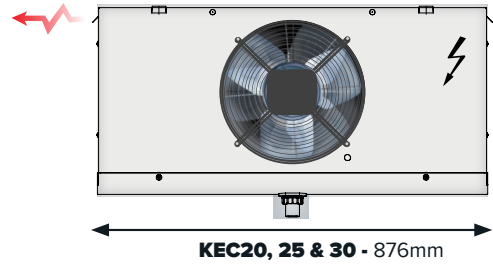
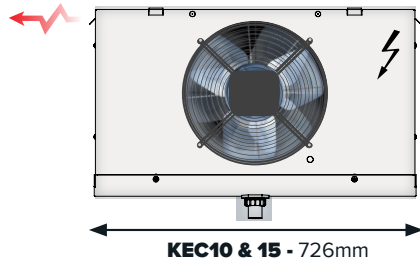
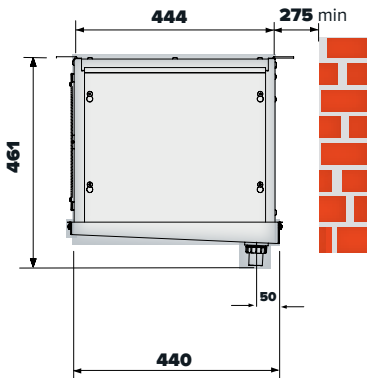

NOTE: heater removal 600mm (either end) Maintenance access Required both ends of unit, All dimensions in mm

HANGING BRACKET FOR ALL KEC MODELS

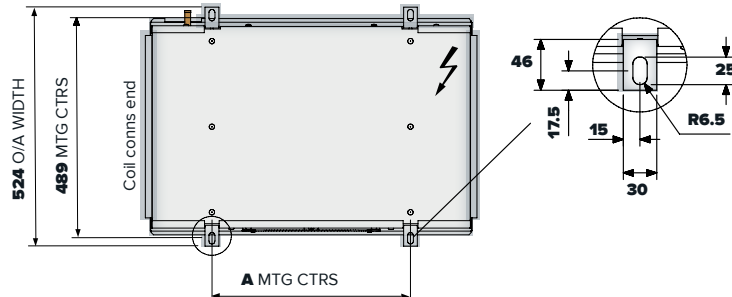

MODEL	DIM A
KEC10 & KEC15	435
KEC20, KEC25, KEC30	585
KEC35, KEC40, KEC45	1035
KEC55 & KEC70	1535